

*ATIS 114.5	V C BIRD Approach 119.1	V C BIRD Tower 1000-2200 UTC 118.2	2200-1000 UTC 119.1	Ground 121.9
VOR ANU 114.5	Final Apch Crs 242°	Minimum Alt D6.0 1600' (1580')	MDA(H) 660' (640')	Apt Elev 60' TDZE 20'
MISSED APCH: LEFT climbing turn to 061° heading, climb to 2000', then LEFT turn to return to ANU VOR at 2500' and hold, or as directed by ATC.				2500'
Alt Set: hPa	TDZ Elev: 1 hPa	Trans level: FL 40	Trans alt: 2500'	MSA ZDX NDB

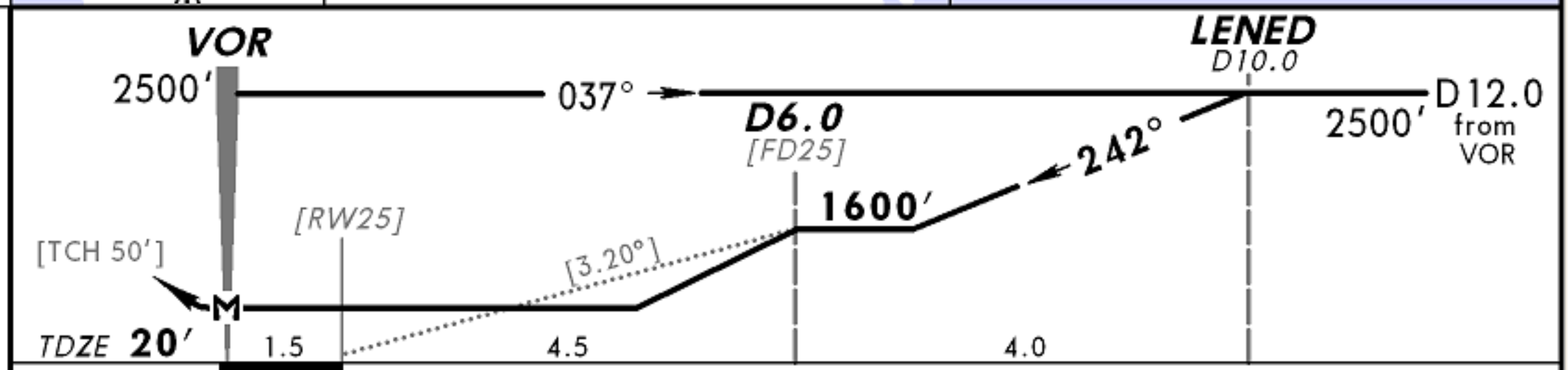
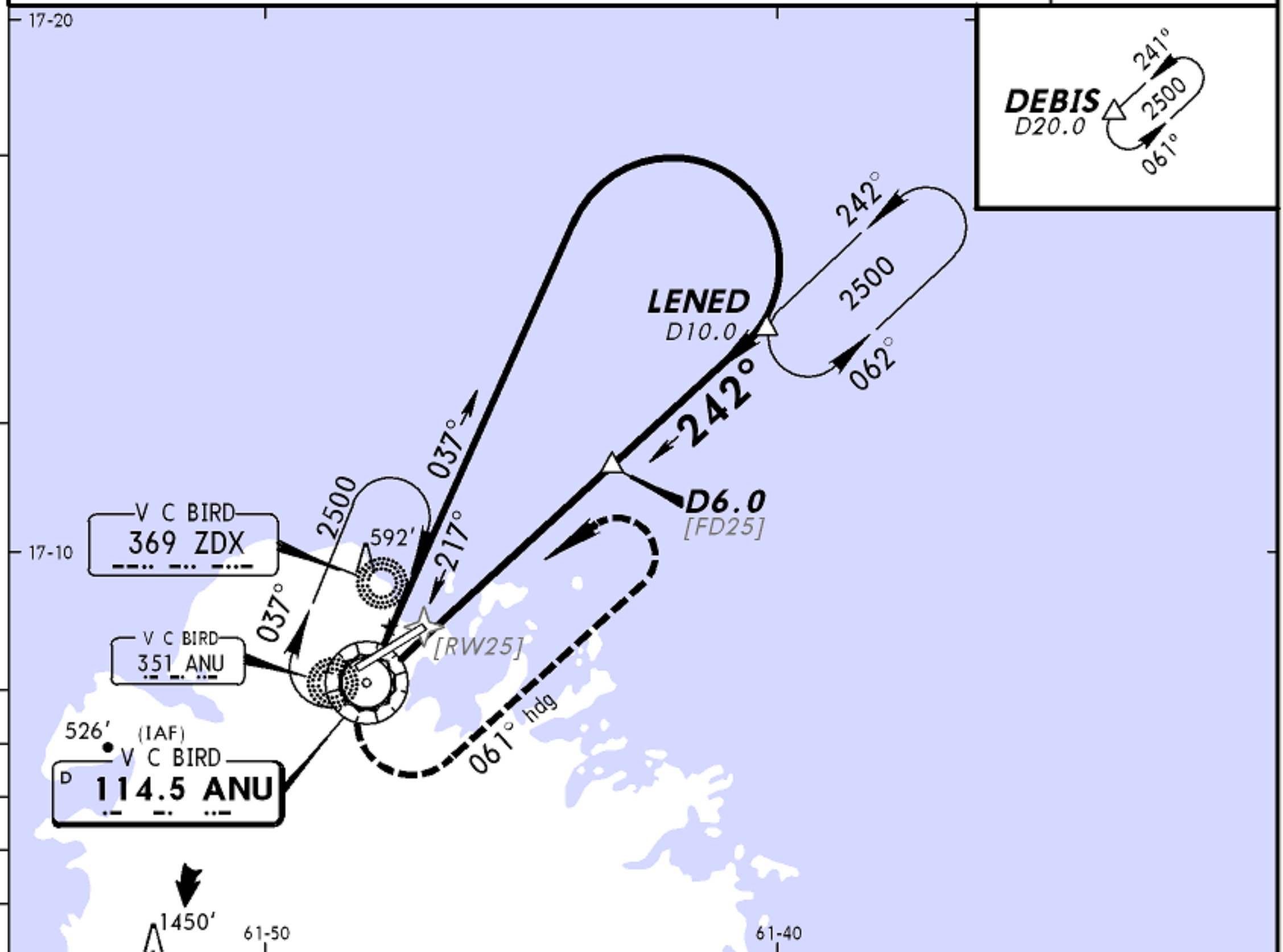

Gnd speed-Kts	70	90	100	120	140	160				
Descent angle [3.20°]	396	510	566	679	793	906				
MAP at VOR										

STRAIGHT-IN LANDING RWY 25		CIRCLE-TO-LAND		
MDA(H) 660' (640')		South of Rwy 07/25	North of Rwy 07/25	
A	2800m	Max Kts	MDA(H)	
		100	700' (640')-2800m	890' (830')-2800m
B		135	740' (680')-2800m	
C		180	930' (870')-3600m	990' (930')-3600m
D	3200m	205	1770' (1710')-4000m	1000' (940')-4000m